



I-9602LW
Addressable Gas Detector



Installation and Operation Manual

Issue 1.01 May 2006
ERP-96103598

CONTENTS

I	Description	1
II	Connection & Wiring	1
III	Installation	2
IV	Application	5
V	Maintenance	6
VI	Caution.....	7
VII	Specification.....	8
VIII	Limited Warranty.....	9

I Description

I-9602LW Addressable Gas Detector is used to detect leakage of natural gas in such areas as houses, hotels and apartments.

II Connection & Wiring

Terminal of the detector is as in Fig. 1.

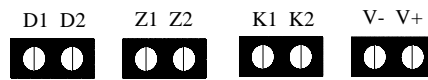

Fig. 1

Terminal description:

D1, D2: Connecting with non-polarized 24VDC power cable.

Z1, Z2: Connecting with loop, non-polarized.

V+, V-: Connecting with pipe solenoid valve. There is a forward 12V pulse between these two terminals if the detector alarms for 3 to 7 seconds continuously.

K1, K2: 24V/1A normally open voltage-free contact which closes if the detector alarms.

Warning: It's prohibited to drive 220VAC equipment through K1 and K2.

Recommended Wiring:

The power cable connecting with D1 and D2 shall be 2.5mm² or above flame-retardant copper-core. Cable connecting with Z1 and Z2, V+ and V- and K1 and K2 shall be 1.0mm² or above flame-retardant copper-core.

III Installation

The detector is suitable for the installation that cables are hidden behind it. Please pull out the cables from the electric box through the hole on the center of the base, then install the base onto the electric box and then connect the cables to corresponding terminals according to the terminal mark and this installation and operation manual. And finally install the detector onto the base. Please refer to Fig. 2 for the installation method.

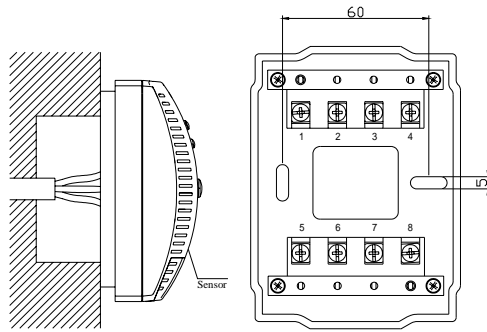

Fig. 2

The detector is wall-mounted (Fig. 3) whose location should be decided according to the type of gas and the position of stove. But there are some general rules to follow:

- ✧ The detector should be placed in the same room with the stove.
- ✧ The vertical distance from the detector to the gas source or stove should be not less than 50cm.
- ✧ The location of the detector to the gas source or stove should be within 1.5 to 4 meters.

To use the detector correctly and avoid any possible trouble, please do not mount the detector at the following locations:

- ✧ Where affected by smoke or vapor from the stove.
- ✧ Where near strong airflow, such as air-inlets, fans, doors, etc.
- ✧ Where near bathroom or places with a lot of vapor.
- ✧ Rooms for boiling water and places where power is cut at night.
- ✧ Where temperature is below -10 or over 50 or outdoors.
- ✧ Where explosion-proof measures are required.
- ✧ Where the detector is partitioned with the gas devices.

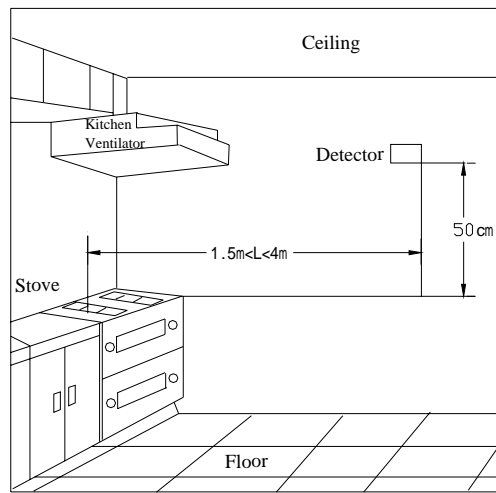

Fig. 3

IV Application

- 1 Applying power supply to the detector after wiring and checking, the green LED will flash for 3 to 6 minutes for warm-up, and then it will

illuminate steadily to indicate the detector has entered normal standby status.

- 2 If the detector alarms, the *Alarm/Fault* LED flashes red, and the buzzer sounds about twice every second. If the detector is in trouble, the *Alarm/Fault* LED illuminates yellow steadily, and the buzzer sounds once every 3 seconds.
- 3 There is a *Self Test* button on the detector to test if the LEDs and buzzer works normally. Pressing the *Self Test* button, the LEDs flash once in turn, and the buzzer sounds three times.

V Maintenance

- 1 The detector should be tested every 6 months. It's allowed to use a gas cigarette lighter to test the detector. Put the lighter near the sensor (over 10cm) press its switch to turn it on and then blow off the flame. The detector should alarm in about 10 seconds.
- 2 Please replace the sensor every 5 years.
- 3 The detector will normally be a bit hot in operation.

VI Caution

- 1 Each type of detector can only detect the kind of gas nominated on its label.**
- 2 Don't install the detector at locations with high temperature (near stoves) or too much smoke (near kitchen ventilator); Keep environment around the detector clean.**
- 3 The detector can only work with the JJ or FCR series solenoid coming with the detector. If other models are to be used, please consult us.**
- 4 Never cut down the power of the detector.**
- 5 If the detector has been stored with power shut off, it will not work steadily during the first 5 hours of power-up for warm-up.**

VII Specification

Power Voltage	24VDC
Loop Voltage	Loop 24V
Normal Standby Power Consumption	≤0.5W
Alarm Power Consumption	≤3W
Type of Gas	Natural gas
Alarm Threshold	6%LEL(methane)
Life of the Sensor	5 years
Ingress Protection	IP30
Temperature	-10 ~ +50
Relative Humidity	≤95%, non-condensing
Material and Color	ABS, ivory white
Weight	180g (with base)
Dimension (L×W×H)	121mm×87mm×57mm (with base)
Mounting Hole Spacing	60mm

VIII Limited Warranty

GST warrants that the product will be free from defects in design, materials and workmanship during the warranty period. This warranty shall not apply to any product that is found to have been improperly installed or used in any way not in accordance with the instructions supplied with the product. Anybody, including the agents, distributors or employees, is not in the position to amend the contents of this warranty. Please contact your local distributor for products not covered by this warranty.



GST China
Gulf Security Technology Co., Ltd.

No. 80, Changjiang East Road, QETDZ, Qinhuangdao, Hebei,
P. R. China 066004
Tel: +86 (0) 335 8502528
Fax: +86 (0) 335 8508942
Email: sales@gst.com.cn
www.gst.com.cn

GST UK
Global System Technology PLC

Enterprise Glade, Bath Lane, Moira, South Derbyshire,
England. DE12 6BD
Tel: + 44 (0) 1283 225 478
Fax: + 44 (0) 1283 220 690

GST Dubai
Global System Technology PLC

PO Box 17998 Unit ZA04 JEBEL ALI Free Zone,
Dubai, UAE
Tel: +971 (0) 4 8833050
Fax: +971 (0) 4 8833053
Email: tech.support@gst.uk.com
www.gst.uk.com